

---

**Virginia Department of Mines, Minerals & Energy**  
**Division of Mines**

---

**Accident Investigation Report**  
**Underground Coal Mine**

**Electrocution**  
**September 24, 2004**

**Cumberland River Coal Company**  
**Fork Ridge Mine**  
**Mine Index No. 14718AA**  
**Wise County, Virginia**

---

**CONTENTS**

Sketches/Photographs . . . . .	1-10	Conclusion. . . . .	30
Commentary . . . . .	11	Enforcement Action. . . . .	30
Statements From Mine Personnel . . . . .	15	Recommendations . . . . .	31
Physical Factors. . . . .	23	Appendix . . . . .	33

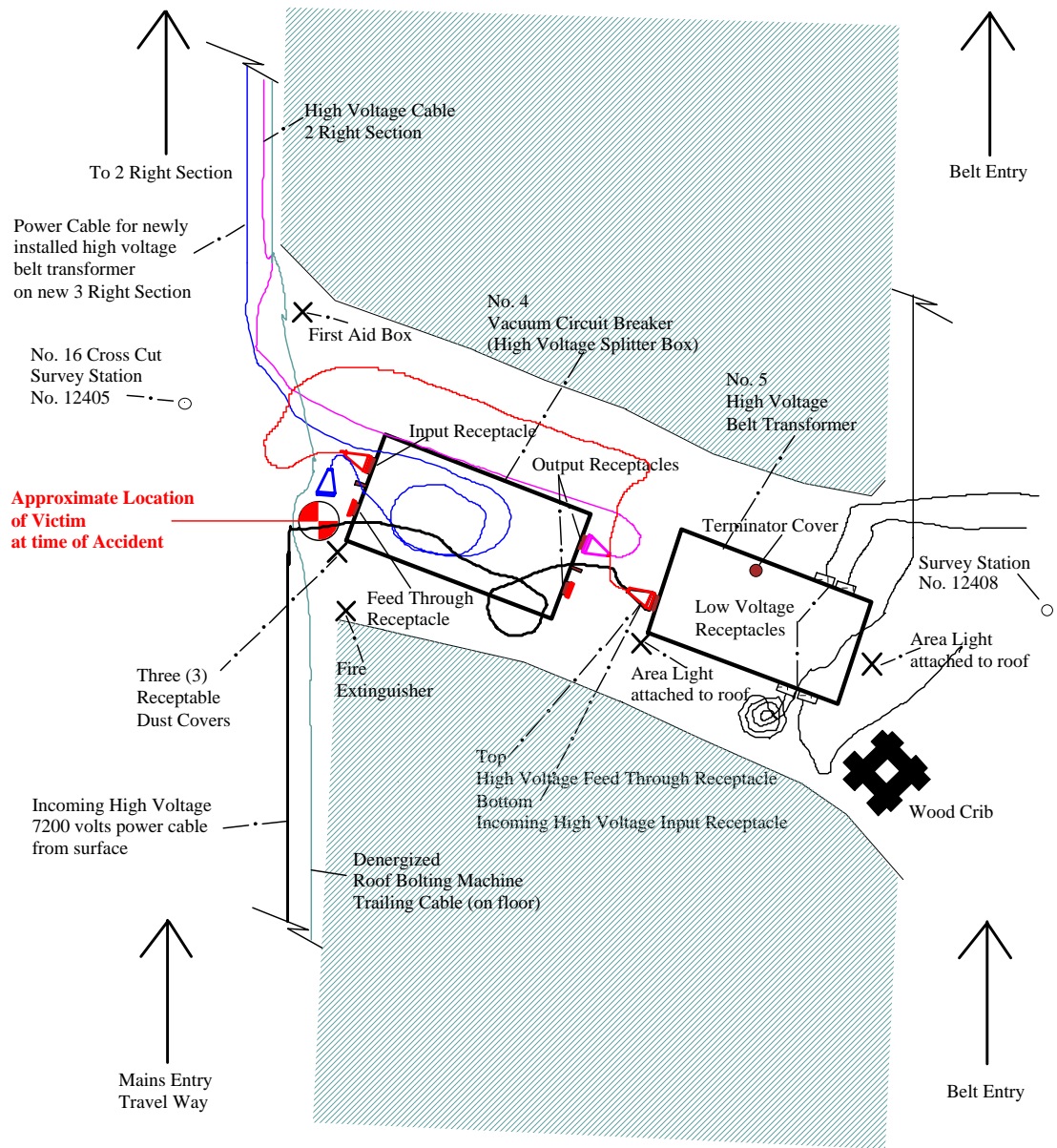

Fatal Accident Scene  
 Cumberland River Coal Company  
 Fork Ridge Mine  
 Mine Index No. 14718AA  
 September 24, 2004

Scale: 1 inch = 8 feet

**Fatal Accident Scene  
Cumberland River Coal Company  
Fork Ridge Mine  
Mine Index No. 14718AA  
September 24, 2004**

**Female receptacle involved in accident - coworker put dust cover back on after accident**

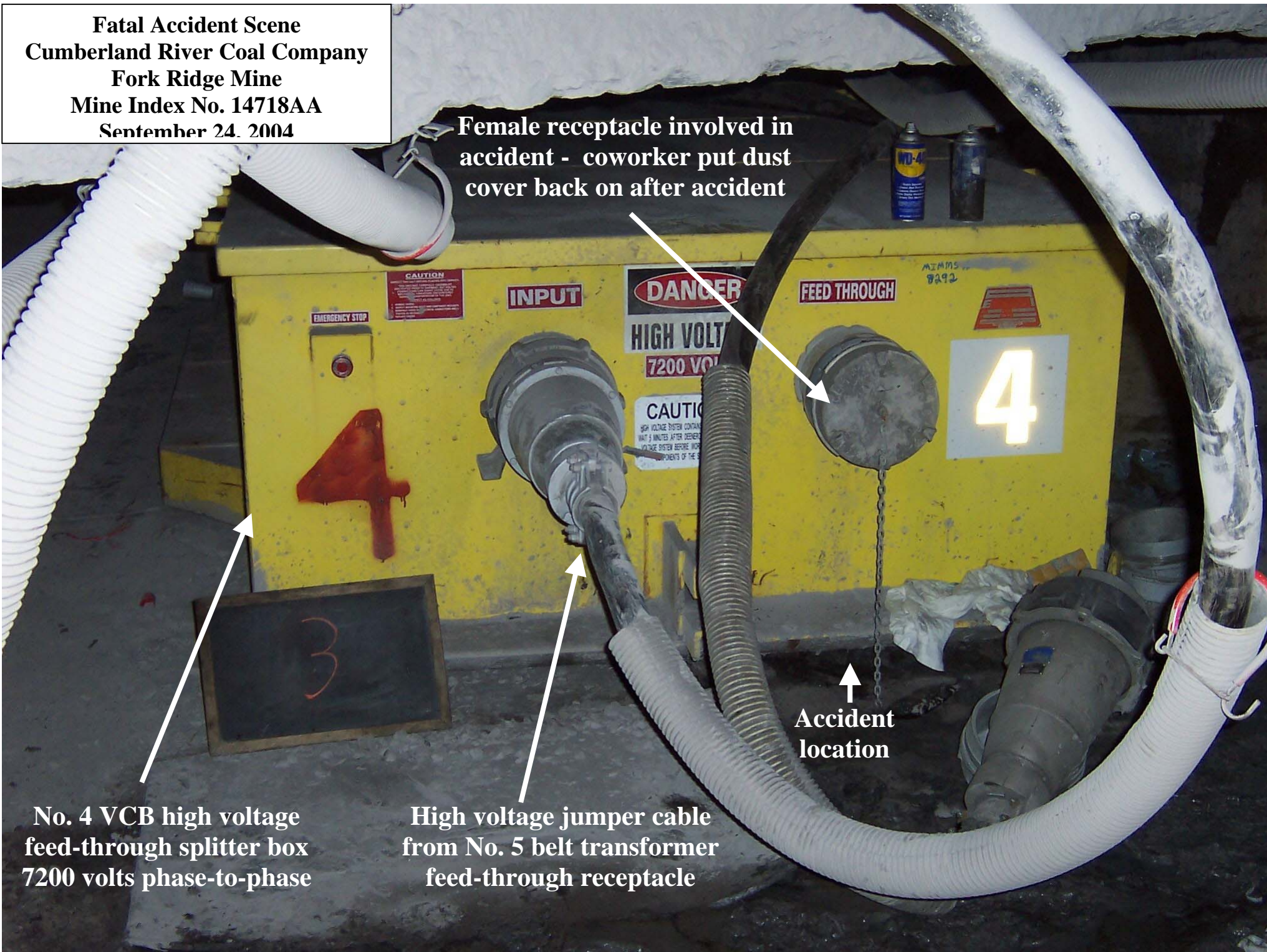

**No. 4 VCB high voltage feed-through splitter box 7200 volts phase-to-phase**

**High voltage jumper cable from No. 5 belt transformer feed-through receptacle**

**↑  
Accident location**

**Fatal Accident Scene  
Cumberland River Coal Company  
Fork Ridge Mine  
Mine Index No. 14718AA  
September 24, 2004**

**Contact Point**

**Victim was attempting to clean dirt, etc. off the high voltage terminals inside the red rubber insulator. Victim contacted a metal conductor inside insulator**



**7200 VOLTS**

**CAUTION**  
HIGH VOLTAGE SYSTEM CONTAINS CAPACITORS  
WAIT 5 MINUTES AFTER DEENERGIZING THE HIGH  
VOLTAGE SYSTEM BEFORE WORKING ON ANY  
COMPONENTS OF THE SYSTEM

**Rubber Insulator  
(on all 3 phases)**

**4**

**No. 4 VCB high voltage  
feed-through splitter box**

**Female receptacle  
involved in accident**

**3 Phase electrical system  
7200 Volts phase to phase  
4160 Volts phase to ground**

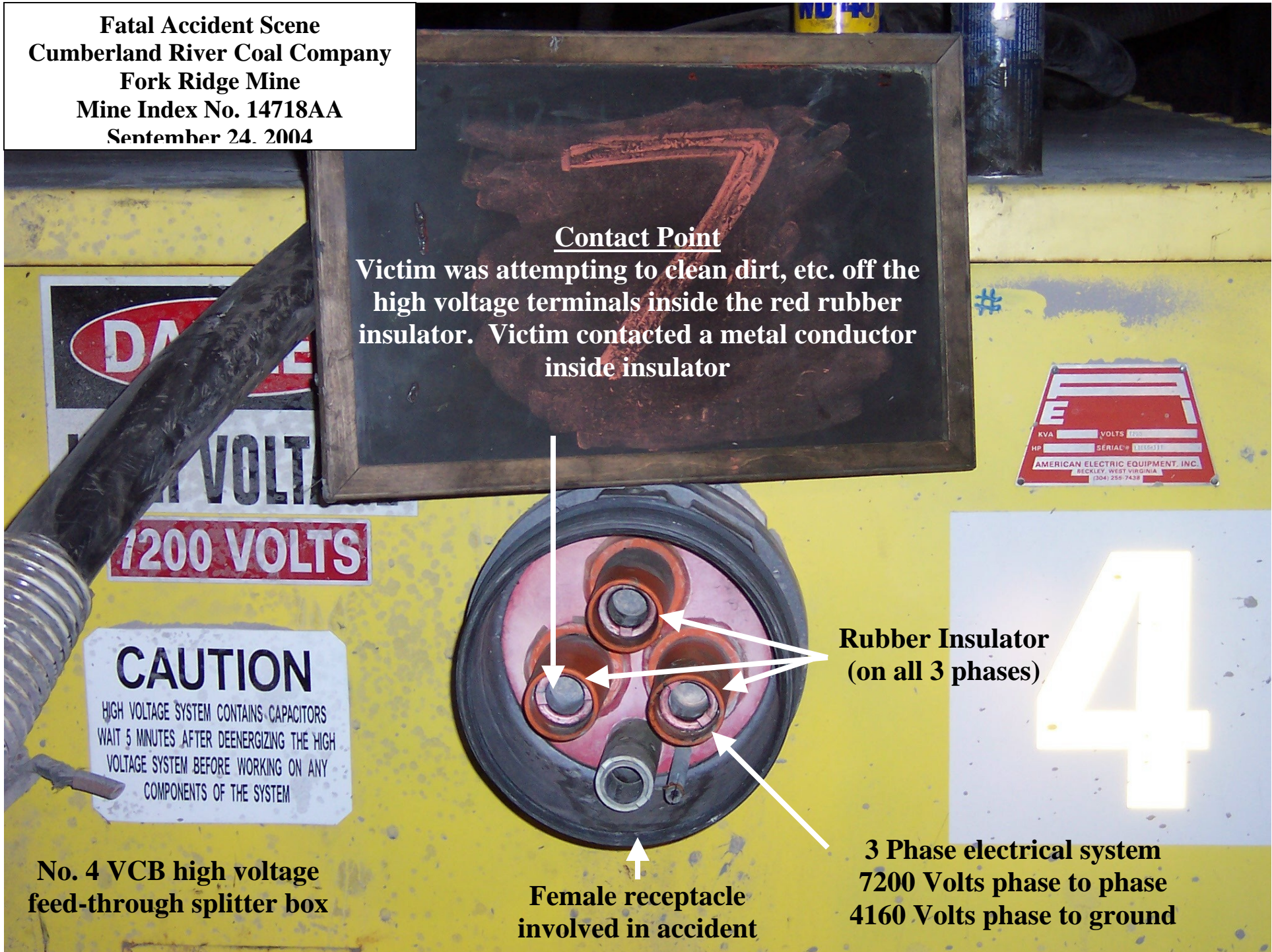

**Fatal Accident Scene  
Cumberland River Coal Company  
Fork Ridge Mine  
Mine Index No. 14718AA  
September 24, 2004**

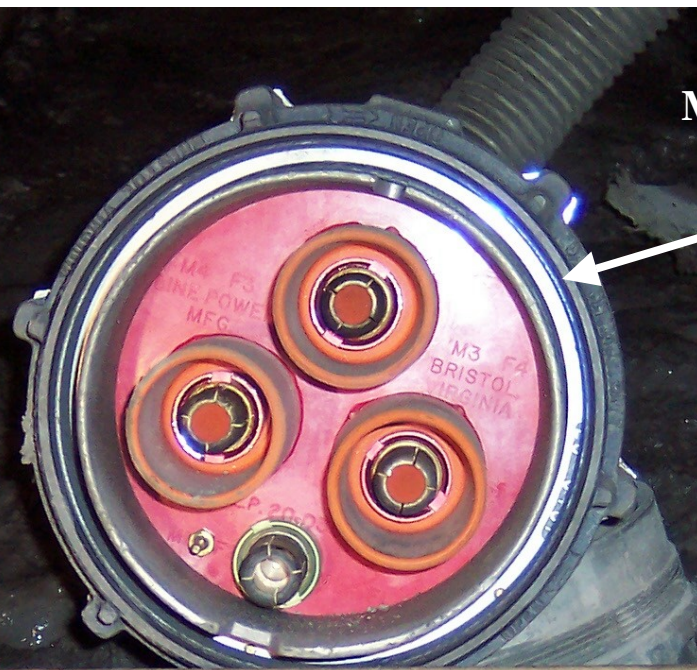

**Male coupler that would  
be connected to the  
female receptacle  
involved in accident**



**Fatal Accident Scene  
Cumberland River Coal Company  
Fork Ridge Mine  
Mine Index No. 14718AA  
September 24, 2004**

**High voltage jumper cable  
to No. 4 VCB high voltage  
splitter box**

**Male coupler - ground  
monitor pin bent inside**

**Feed-through receptacle**

**Input receptacle**

**No. 5 High voltage belt  
transformer**

**Incoming high voltage  
power cable from surface**

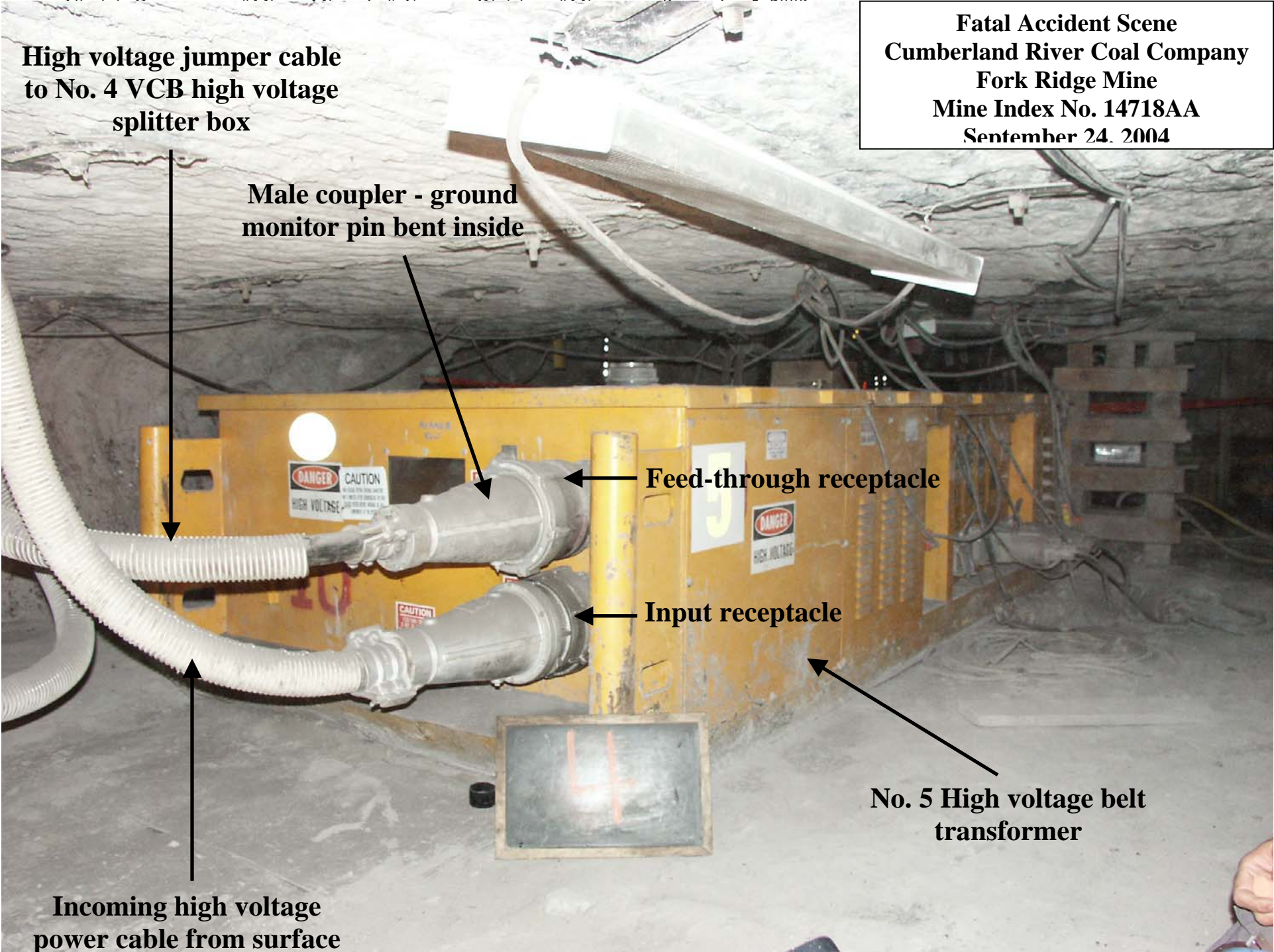

**Fatal Accident Scene  
Cumberland River Coal Company  
Fork Ridge Mine  
Mine Index No. 14718AA  
September 24, 2004**

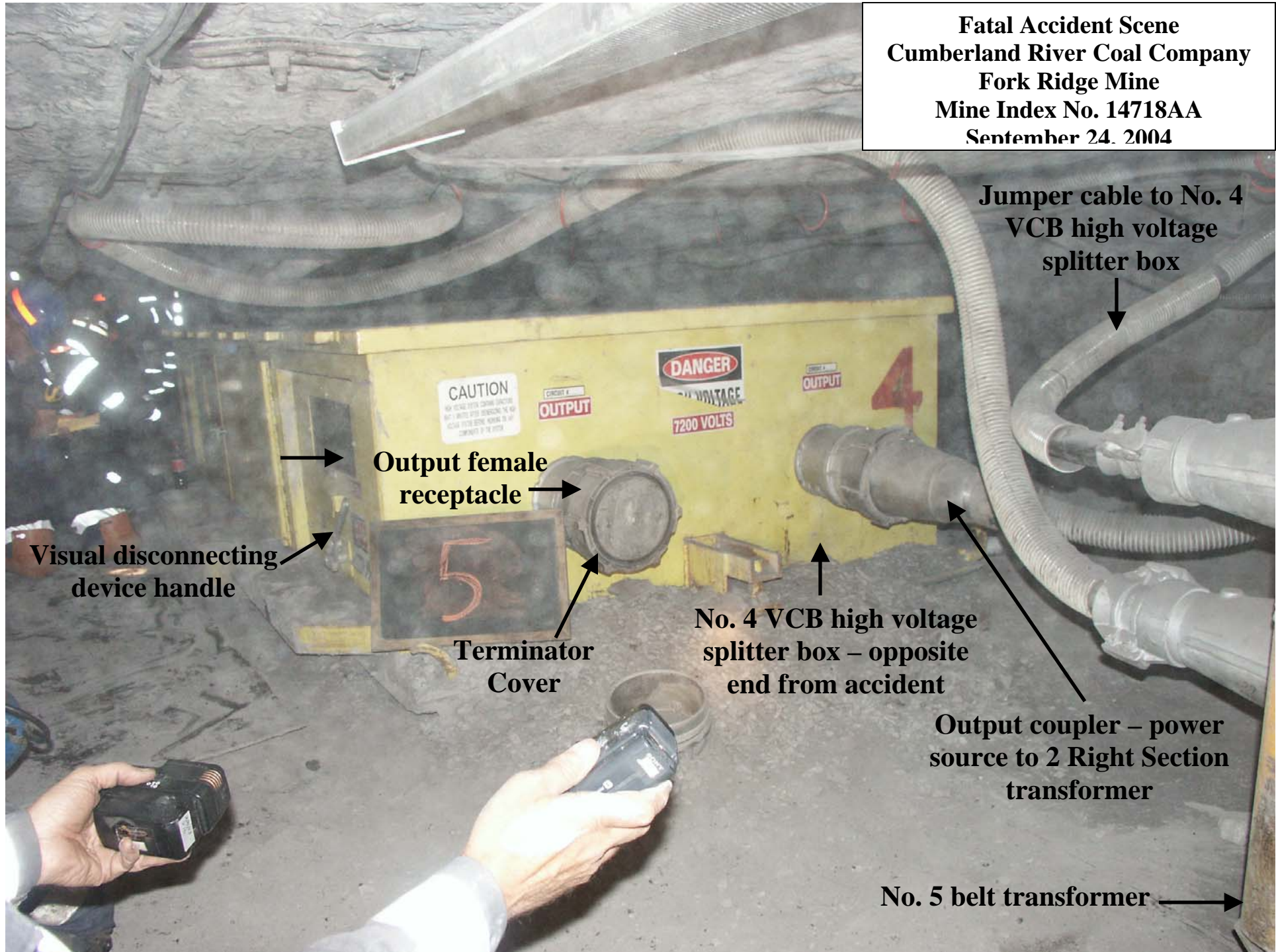

**Jumper cable to No. 4  
VCB high voltage  
splitter box**

**Output female  
receptacle**

**Visual disconnecting  
device handle**

**Terminator  
Cover**

**No. 4 VCB high voltage  
splitter box – opposite  
end from accident**

**Output coupler – power  
source to 2 Right Section  
transformer**

**No. 5 belt transformer**

**Fatal Accident Scene  
Cumberland River Coal Company  
Fork Ridge Mine  
Mine Index No. 14718AA  
September 24, 2004**

**Male coupler  
connected to No. 5  
high voltage belt  
transformer feed-  
through receptacle**

**Ground monitor pin-  
observed bent against  
coupler housing**





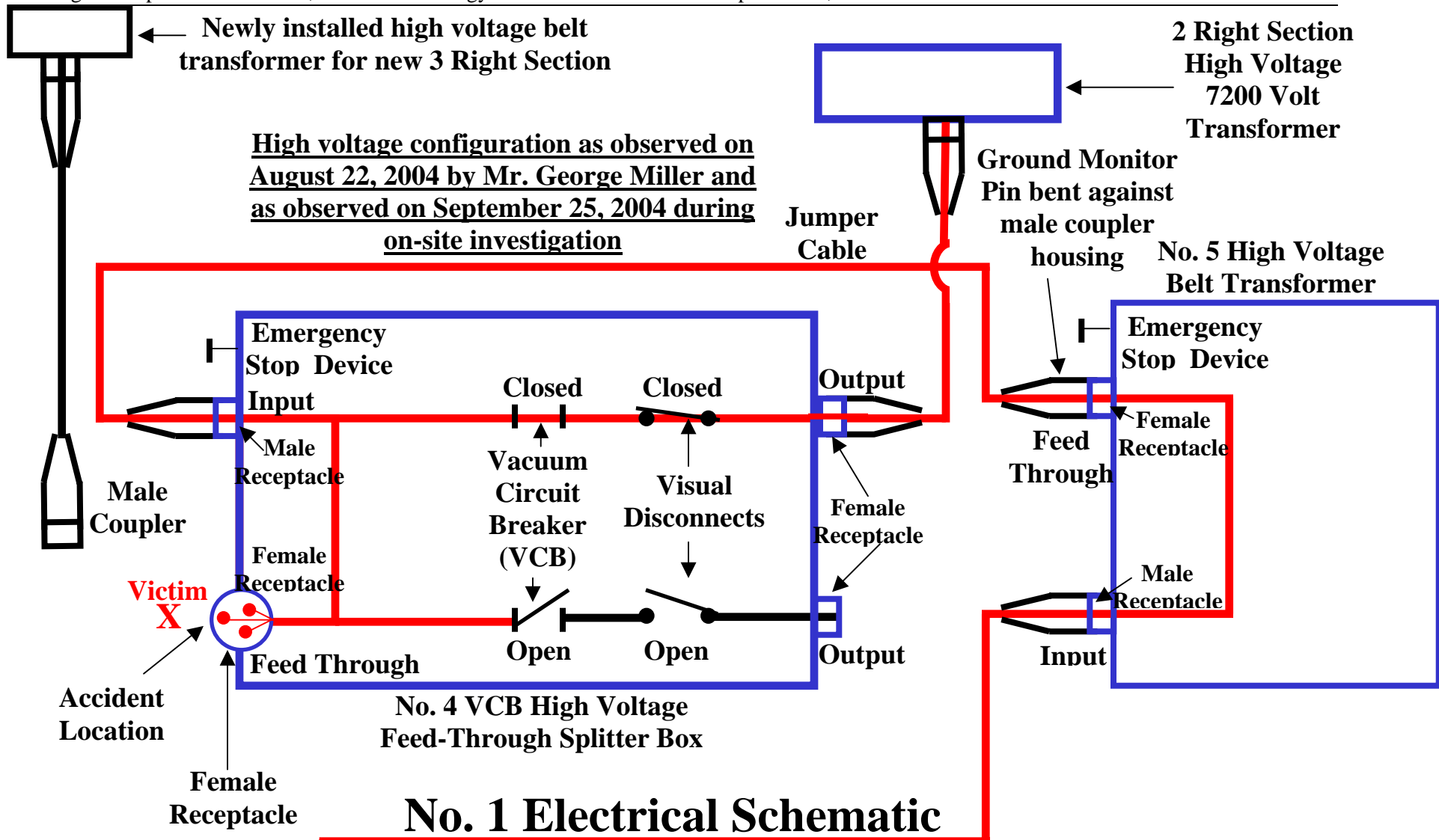

**RED** – Energized power when accident occurred  
 7200 Volts Phase to Phase  
 4160 Volts Phase to Ground

**Incoming High Voltage Power Cable From Surface**

**Fatal Accident Scene  
 Cumberland River Coal Company  
 Fork Ridge Mine  
 Mine Index No. 14718AA  
 September 24, 2004**

Virginia Department

**High voltage configuration as originally installed on July 21, 2004 by Mr. George Miller - 3<sup>rd</sup> shift electrical repairman**

To No. 2 Right Section High Voltage 7.200 Volt Transformer

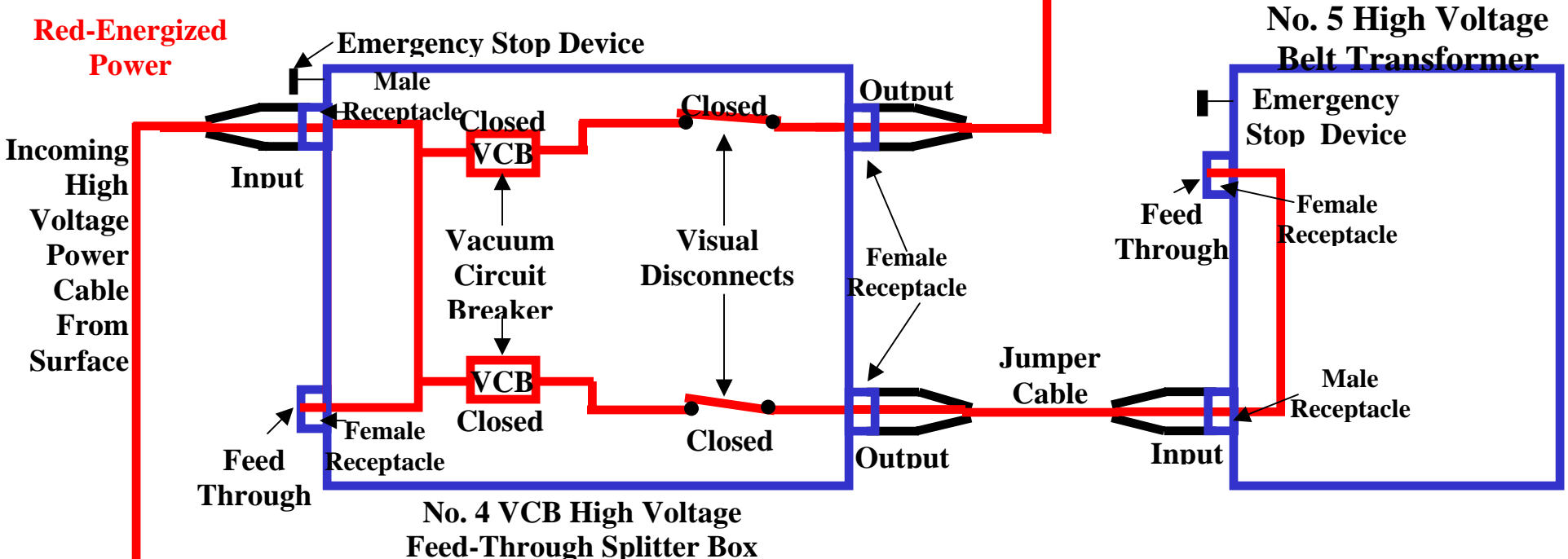

**No. 2 Electrical Schematic**

Fatal Accident Scene  
 Cumberland River Coal Company  
 Fork Ridge Mine  
 Mine Index No. 14718AA  
 September 24, 2004

**FATALITY INVESTIGATION  
CUMBERLAND RIVER COAL COMPANY, INC.  
FORK RIDGE MINE  
MINE INDEX NO. 14718AA  
SURFACE SUBSTATION INFORMATION**

**Substation Data**Location: SurfaceDate: September 25, 2004**Transformer(s)**Primary Voltage: 34,500 VACSecondary voltage: 7,200 VACKVA: 2000Primary fuses: 30 ampsTransformer connections: Primary: DeltaSecondary: Wye**High Voltage Circuit Breaker**Mfg.: WestinghouseType: ESMMax Volts: 14.4 KVMaximum Current: 600 ampsC.T. Ratio 60:1Phase Overcurrent Relays. Mfg.: WestinghouseType: CO 9Tap: 3Instantaneous Setting: 20Time Dial Setting: 3

Ground Fault Relay:

Mfg.: WestinghouseType: CO 11Tap: 0.5**Grounding Resistor**Mfg.: HubbellVoltage Rating: 8,700Resistance: 156C.T. Ratio: 50:5and/or P.T. Ratio: N/AAmps: 26Ground Field Resistance: 6**High Voltage Ground Monitor**Mfg.: Mining Controls Inc.Type: 22701-4Current Reading: 2 amps**Underground High Voltage Feeder Cable**Size: 4/0 AWG No. Of Conductors: 3 Type: GGC - SHDMfg.: American Insulated Wire (AIW)Voltage Rating: 15KV

**ELECTROCUTION ACCIDENT FATALITY INVESTIGATION REPORT  
CUMBERLAND RIVER COAL COMPANY  
FORK RIDGE MINE  
MINE INDEX NO. 14718AA**

On September 24, 2004, at approximately 8:30 p.m., an underground high voltage electrical power accident occurred at Cumberland River Coal Company, Fork Ridge Mine, Mine Index No. 14718AA. Mr. Leonard Halcomb, face equipment operator, was fatally injured when he came in contact with one phase of an energized 7,200 volt, phase to phase, high voltage terminal located in a high voltage feed-through splitter box female receptacle. Mr. Halcomb and a coworker were cleaning and preparing a high voltage female receptacle and a male coupler that were to be connected and were scheduled to be energized on the next shift to provide electrical power to a new working section high voltage belt transformer. Mr. Halcomb, age 51, had 30 years total mining experience, seven years and six months experience with the present company and one year and two months employment at the Fork Ridge Mine. The Department of Mines, Minerals and Energy's Division of Mines was notified of the accident at approximately 9:30 p.m. on September 24, 2004, and a joint investigation with the Federal Mine Safety and Health Administration was initiated the same day. The mine is scheduled to receive one regular inspection every six months. The last regular inspection was completed on July 7, 2004.

## **COMMENTARY**

Cumberland River Coal Company, Fork Ridge Mine is located off State Route 603 in Wise County, Virginia. This underground mine is a one-section drift mine developed approximately 5,700 feet in the Taggart coal seam. Approximately 1,200 tons of raw coal are produced daily using a Joy 14 CM10-11X continuous miner and a Stamler continuous haulage bridge system. Mining personnel produce coal on the day and evening shifts with maintenance work performed on the third shift.

On Friday, September 24, 2004, the evening shift production crew entered the mine at approximately 3:00 p.m., under the supervision of Mr. Jerry Edwards, section mine foreman. The production crew arrived on the 2 Right Section off the Mains at approximately 3:15 p.m., and production activities proceeded as normal until the accident occurred.

Second mining (pillaring) activities were near completion on the 2 Right Section. Mining personnel had installed various electrical equipment, including a high voltage belt transformer, on the Mains near where the (new) 3 Right Section would be developed.

Mr. Halcomb and Mr. Rodney Brooks, repairman, normally received their work instructions from Mr. Tommy Duncan, Chief Electrician, or Mr. Edward Creech, Mine Superintendent.

Mr. Halcomb and Mr. Brooks, who normally worked together, began their shift on the surface at 3:00 p.m. As the production crew traveled underground to produce coal, Mr. Halcomb and Mr. Brooks remained on the surface to build and install metal guards on a belt drive that would be taken underground soon and would be used on the (new) 3 Right Section. Mr. Halcomb and Mr. Brooks had been instructed by Mr. Duncan to install guards on a belt drive that

would be utilized on the new section, and to prepare electrical connections for the (new) 3 Right Section high voltage belt transformer which would receive electrical power from the No. 4 vacuum circuit breaker (VCB) high voltage feed-through splitter box. The No. 4 VCB high voltage splitter box was powered with standard, mine wide, 7,200 volts, phase-to-phase, alternating current (AC).

Mr. Halcomb and Mr. Brooks completed their assigned work on the surface and entered the mine between 6:00 p.m. and 7:00 p.m. They traveled to the Mains where the (new) 3 Right Section would be started. Upon their arrival at the (new) 3 Right Section, Mr. Brooks and Mr. Halcomb prepared and connected a high voltage male coupler to a female receptacle, located on the newly installed high voltage belt transformer that would be used for the new section. At this time, Mr. Brooks observed that a "terminator cover" was missing on the belt transformer. Mr. Brooks and Mr. Halcomb began to search for a "terminator cover" and eventually found one lying on top of the No. 5 high voltage belt transformer, located immediately adjacent to the No. 4 VCB high voltage splitter box. Mr. Brooks was not sure that the "terminator cover" that he and Mr. Halcomb had found was the proper type, so he and Mr. Halcomb traveled to the surface to look for another "terminator cover". While located on the surface, Mr. Brooks and Mr. Halcomb found a "second terminator cover". As Mr. Brooks was not sure if he had the proper type terminator cover, he called Mr. Duncan at home to determine if he had the proper cover. After Mr. Brooks described the terminator covers to Mr. Duncan, Mr. Duncan informed Mr. Brooks that the covers that he had found were the proper type. Mr. Brooks and Mr. Halcomb then returned to the Mains, where the (new) 3 Right Section would be developed, and installed the terminator cover on the newly installed belt transformer.

After Mr. Brooks and Mr. Halcomb completed their assigned work on the Mains at the (new) 3 Right Section, they traveled to the No. 4 VCB high voltage splitter box.

The No. 4 VCB high voltage splitter box was located at survey station No. 12408, immediately adjacent to the No. 5 high voltage belt transformer that provided electrical power to the 2 Right Section belt conveyor. The incoming high voltage 7,200 volt power source from the surface was connected to the No. 5 belt transformer "input" and had an output jumper cable that provided high voltage power from a "feed-through" receptacle to an "input" receptacle located on the No. 4 VCB high voltage splitter box. This high voltage input on the No. 4 VCB splitter box was located on the same end of the box where the female receptacle was located that was involved in the accident. The high voltage feed-through electrical circuit that provided power to the female receptacle was connected on this input/feed-through end of the No. 4 VCB splitter box where the accident occurred.

Mr. Brooks and Mr. Halcomb had also been instructed to "prepare" which included cleaning and connecting the high voltage, male coupler to the female receptacle located on the No. 4 VCB high voltage splitter box that would provide electrical power to the new belt transformer, recently installed on the Mains at the (new) 3 Right Section location. The male coupler was attached to the other end of the high voltage cable that Mr. Brooks and Mr. Halcomb had connected to the new belt transformer. Mr. Brooks and Mr. Halcomb had been instructed to prepare and connect the high voltage cable but not to energize this circuit. This high voltage circuit was scheduled to be energized and tested on the next shift.

Upon the arrival of Mr. Brooks and Mr. Halcomb at the No. 4 VCB high voltage splitter box, Mr. Brooks observed that the vacuum circuit breaker (VCB) was deenergized on the right side of the box as viewed from the input/feed-through end. This vacuum circuit breaker (VCB) was located on the same side and in-line with the female receptacle involved in the accident.

The splitter box has two high voltage circuits and is equipped with a control power circuit breaker, a vacuum circuit breaker (VCB) and a visual disconnecting device for each high voltage circuit that is located on each side of the box. Mr. Brooks thought that the control power circuit breaker, VCB and disconnecting device located on the right side of the splitter box was the circuit that provided electrical power to the female receptacle, also located on the right side of the box that he and Halcomb had been instructed to prepare and connect to the male coupler. As Mr. Brooks and Mr. Halcomb were performing work at the No. 4 VCB splitter box, Mr. Randall Middleton, bridge operator, came by their location traveling in an outby direction while looking for a piece of continuous miner water line that was needed on the 2 Right Section.

Mr. Brooks then deenergized the control power circuit breaker and "opened" (deenergized) the visual disconnecting device, both of which were located on the right side of the No. 4 VCB high voltage splitter box. Mr. Brooks looked through the clear plastic window located on the right side of the No. 4 VCB splitter box at the visual disconnecting device handle to ensure the high voltage blades had "opened" (deenergized) and grounded. With the control power circuit breaker and the vacuum circuit breaker (VCB) deenergized and the visual disconnecting device open (deenergized) on the right side of the splitter box, Mr. Brooks and Mr. Halcomb apparently thought that the electrical power had been deenergized to the female receptacle that they planned to clean, which also was located on the right side of the splitter box. Mr. Brooks and Mr. Halcomb failed to recognize that the female receptacle was energized with 7,200 volts, phase to phase, that was provided by the input/feed-through high voltage circuit located on the same end of the box as the female receptacle. Mr. Brooks thought that the high voltage feed-through electrical circuit was located on the opposite "output" end of the No. 4 VCB splitter box, and that with the visual disconnecting device in the open (deenergized) position that electrical power was deenergized at the female receptacle involved in the accident.

Mr. Brooks removed the male coupler that was lying on top of the No. 5 high voltage belt transformer that was located immediately adjacent to the No. 4 VCB high voltage splitter box. A plastic trash bag had been placed over the male coupler and taped to the adjoining cable to keep the coupler clean. Mr. Brooks removed the plastic trash bag and cleaned the male coupler with a piece of cloth. Mr. Brooks removed a "dust cover" that had been installed over the female receptacle. Feed-through female receptacles are designed with electrical control circuits that require a "terminator cover" to keep the high voltage power energized, if the ground/ground-monitoring circuit is operating properly.

At this time, Mr. Brooks was standing near Mr. Halcomb as both men were located at the input/feed-through end of the No. 4 VCB high voltage splitter box. Mr. Brooks departed Mr. Halcomb's immediate location and walked approximately 20 feet across the regularly traveled haulway where their mantrip was parked in a crosscut across from the No. 4 VCB splitter box. Mr. Brooks was going to get a drink of pop or water from his lunch bucket located on the mantrip. Mr. Halcomb was standing near the female receptacle at the input/feed-through end of the No. 4 VCB high voltage splitter box when Mr. Brooks walked to the mantrip. At this time, apparently Mr. Halcomb decided to clean the female receptacle. As Mr. Brooks was standing near the mantrip, he heard Mr. Halcomb yell something like "Oh" or "Damn" or something like that. Mr. Brooks turned to face Mr. Halcomb and observed him standing with his arms to his sides, at an arms length distance - approximately two feet away from the female receptacle. Mr. Brooks ran immediately to Mr. Halcomb's location and as he got near, Mr. Halcomb was trying to slump to his knees. Mr. Brooks began asking Mr. Halcomb if he was alright but never received any response. Mr. Halcomb continued slumping to his knees with his head held in an

upright position as Mr. Brooks continued to try to get a response. Upon Mr. Halcomb reaching his knees, he began making breathing sounds that Mr. Brooks described as “snoring”. Mr. Brooks laid Mr. Halcomb on the mine floor, as he continued to try to get a response, but was unsuccessful. Mr. Brooks attempted to load Mr. Halcomb on the mantrip but physically was unable to do so. Mr. Brooks said that because he couldn’t get any type response from Mr. Halcomb and because of the breathing sounds (snoring) that he heard, he thought Mr. Halcomb was unconscious. Mr. Brooks departed Mr. Halcomb’s location to get help and traveled outby approximately 150 feet where he met Mr. Middleton, who was returning to the 2 Right Section. Mr. Brooks and Mr. Middleton returned to Mr. Halcomb’s location. Mr. Middleton administered first aid to Mr. Halcomb as Mr. Brooks went to a mine telephone, located approximately 42 feet away, to call the 2 Right Section personnel for help. Mr. Brooks returned to Mr. Halcomb’s location and informed Mr. Middleton that he could not contact the 2 Right Section personnel, and then Mr. Brooks informed Mr. Middleton that he would go to the 2 Right Section to get help. After Mr. Brooks departed the accident location, Mr. Middleton went to the mine telephone and contacted the 2 Right Section personnel. Mr. Middleton also contacted surface personnel requesting an ambulance and then returned to Mr. Halcomb’s location. As Mr. Brooks was traveling toward the 2 Right Section to get help, he met Mr. Jerry Edwards, section mine foreman, and other mine personnel, whom Mr. Middleton had notified, who were enroute to the accident scene. Mr. Brooks, Mr. Edwards and other mining personnel returned to the accident scene and began administering cardiopulmonary resuscitation (CPR) on Mr. Halcomb.

As mining personnel were performing CPR on Mr. Halcomb, Mr. Middleton traveled to the 2 Right Section and obtained first aid equipment, including an automatic external defibrillator (AED) from the section first aid equipment box. Upon Mr. Middleton’s return to the accident scene, mine personnel connected the AED to Mr. Halcomb and the AED advised “No Shock” by voice prompt. Mine personnel continued CPR on Mr. Halcomb as they loaded him on a stretcher and onto a mantrip. CPR was continued as Mr. Halcomb was transported to the surface. CPR was continued on the surface and the AED was activated again to analyze Mr. Halcomb’s condition, while awaiting arrival of rescue squad personnel. At this time, the AED responded “Shock Advised” by voice prompt. Mr. Halcomb was defibrillated three times by Appalachia Rescue Squad personnel but all attempts of resuscitation and defibrillation were unsuccessful. Rescue squad personnel assumed responsibility of the victim and departed the mine site while continuing CPR enroute to the Norton Community Hospital. Mr. Halcomb was pronounced dead by Dr. Maurice Nida, Wise County Coroner.

## **STATEMENTS FROM MINE PERSONNEL AND OTHER FACTORS**

Statements from mine personnel and other factors determined during the investigation revealed the following:

Initial interviews of eight (8) mine personnel were conducted on September 27, 2004. Due to confusing statements made by mine personnel relating to changes of high voltage electrical connections made at the No. 4 VCB high voltage splitter box and No. 5 high voltage belt transformer, second interviews of ten (10) mine personnel were conducted on October 21, 2004, in which personnel were placed under oath.

### **Rodney Brooks – Repairman stated:**

1. That there were no eyewitnesses to the accident, but he was located in the general area when the accident occurred;
2. That he and Mr. Halcomb normally worked together and that they began their shift on September 24, 2004, on the surface area of the mine;
3. That he and Mr. Halcomb would routinely be given work instructions by Mr. Edward Creech, mine superintendent, or Mr. Tommy Duncan, Chief Electrician, but on the shift of the accident, they had been assigned by Mr. Duncan to perform this work;
4. That he did not perform high voltage work very often;
5. That while he and Mr. Halcomb were located on the surface, they installed metal guards on a belt drive that would be taken underground soon to be used on the (new) 3 Right Section;
6. That he and Mr. Halcomb completed their assigned work on the surface and proceeded underground between 6:00 p.m. and 7:00 p.m.
7. That he and Mr. Halcomb traveled first to the Mains (new) 3 Right Section, prepared and connected a high voltage female coupler to a male receptacle on the newly installed high voltage belt transformer; the other end of this cable would be connected to the No. 4 VCB high voltage splitter box where the accident occurred;
8. That he observed a “terminator cover” was missing on the newly installed high voltage belt transformer;
9. That he and Mr. Halcomb found one “terminator cover” lying on top of the No. 5 high voltage belt transformer, located adjacent to the No. 4 VCB high voltage splitter box, and that they found another “terminator cap” on the surface;
10. That he called Mr. Duncan, Chief Electrician, at home to verify that the terminator covers that he had found were the proper type;
11. That he and Mr. Halcomb returned to the Mains (new) 3 Right Section and installed a “terminator cover” on the newly installed high voltage belt transformer;
12. That after completing their assigned work at the (new) 3 Right Section belt transformer, he and Mr. Halcomb traveled to the No. 4 VCB high voltage splitter box;
13. That he and Mr. Halcomb had been given work instructions to “prepare”, which included cleaning the male coupler that was attached to the other end of the high voltage cable that they had connected to the newly installed high voltage belt transformer on the Mains at the (new) 3 Right Section; that the other end of this high voltage cable with the attached male coupler would be cleaned and connected to the female receptacle located on the No. 4 VCB high voltage splitter box where the accident occurred;



14. That he and Mr. Halcomb had been given work instructions to “prepare”, which would include cleaning the female receptacle located on the No. 4 VCB high voltage splitter box when the accident occurred;
15. That he and Mr. Halcomb had also been given work instructions to connect the male coupler that would provide 7,200 volts to the (new) 3 Right Section high voltage belt transformer from the No. 4 VCB splitter box; that he and Mr. Halcomb had been instructed to connect the male coupler to the female receptacle but not to energize this circuit as this circuit was scheduled to be energized and tested on the next shift;
16. That when he and Mr. Halcomb initially arrived at the No. 4 VCB high voltage splitter box that the vacuum circuit breaker (VCB) was deenergized on the right side of the box (same side of the box and in-line with the female receptacle involved in the accident);
17. That he thought the control power circuit breaker, VCB and visual disconnecting device located on the right side of the No. 4 high voltage splitter box was the circuit that provided electrical power to the female receptacle, also located on the right side of the box that was involved in the accident;
18. That while he and Mr. Halcomb were located at the No. 4 VCB high voltage splitter box, Mr. Middleton came by their location while traveling outby to get a piece of water line for the 2 Right Section continuous miner;
19. That he deenergized the control power circuit breaker located on the right side of the No. 4 VCB high voltage splitter box, after observing that the vacuum circuit breaker (VCB) was deenergized;
20. That he “opened” (deenergized) the visual disconnecting device, located on the right side of the No. 4 VCB high voltage splitter box, and looked through the clear plastic window at the disconnecting device to verify the high voltage blades had “opened” (deenergized) and grounded;
21. That he thought with the control power circuit breaker and vacuum circuit breaker (VCB) deenergized and the disconnecting device open (deenergized), that all electrical power connected to the female receptacle where the accident occurred had been deenergized;
22. That he removed the male coupler that was lying on top of the No. 5 high voltage belt transformer and removed the trash bag and cleaned the coupler;
23. That he observed a “dust cover” which had been installed over the female receptacle, located on the right side of the No. 4 VCB high voltage splitter box where the accident occurred;
24. That since a “dust cover” had been installed over the No. 4 high voltage splitter box female receptacle involved in the accident, he thought this was the “output” receptacle end of the splitter box, but this was really the input/feed-through end of the splitter box and the “output” receptacle was located on the opposite end of the box in-line with the female receptacle involved in the accident;
25. That he observed a “terminator cover”, which had been installed over the female receptacle also located on the right side of the No. 4 VCB high voltage splitter, in-line and on the output end of the box from the female receptacle involved in the accident;
26. That he departed Mr. Halcomb’s immediate location at the female receptacle end of No. 4 VCB high voltage splitter box and walked across the haulway to their mantrip parked in the adjoining crosscut to get a drink of pop or water from his lunch bucket;

27. That Mr. Halcomb was standing near the female receptacle located on the input/feed-through end of the No. 4 VCB high voltage splitter box, when Mr. Brooks departed to go to his lunch bucket;
28. That after he departed Mr. Halcomb's location, Mr. Halcomb apparently decided to clean the female receptacle;
29. That as he was standing near the mantrip, that he heard Mr. Halcomb yell something like "Oh" or "Damn" or something like that;
30. That he turned to face Mr. Halcomb and observed him standing with arms to his sides at arms length distance, approximately two feet from the female receptacle;
31. That he traveled immediately to Mr. Halcomb's location and attempted to get a response but was unsuccessful;
32. That Mr. Halcomb slumped to his knees and began making breathing sounds that he regarded as "snoring";
33. That he laid Mr. Halcomb on the mine floor, as he continued to try to get a response from Mr. Halcomb, but was unsuccessful, and at this time he thought Mr. Halcomb was unconscious;
34. That he attempted to load Mr. Halcomb on the mantrip, but physically was unable to do so;
35. That he departed Mr. Halcomb's location to get help and traveled outby approximately 150 feet where he met Mr. Middleton who was returning to the 2 Right Section;
36. That he and Mr. Middleton returned to Mr. Halcomb's location and that Mr. Middleton administered first aid to Mr. Halcomb as Mr. Brooks traveled to a mine telephone to request help from 2 Right Section personnel, but was unsuccessful in contacting anyone on the section;
37. That he departed Mr. Halcomb's location, as Mr. Middleton administered first aid, and traveled toward the 2 Right Section and met Mr. Edwards and other mine personnel, who were enroute to the accident location after having been notified by Mr. Middleton;
38. That he returned to the accident location with Mr. Edwards and other mine personnel;
39. That he placed a "dust cover" over the female receptacle involved in the accident as mine personnel were administering first aid to Mr. Halcomb, because he thought the female receptacle may have provided the power source from which Mr. Halcomb received an electrical shock and could pose a hazard to those personnel administering first aid.
40. That he was not sure whether or not he had ever connected or disconnected any of the high voltage male and female couplers connected to the No. 4 VCB high voltage splitter box and No. 5 high voltage belt transformer, and could not recall observing any "alignment guide" screws in the female coupling devices.

**Jerry Edwards – Section Mine Foreman stated:**

1. That he entered the mine at approximately 3:00 p.m., and traveled to the 2 Right Section with the section crew to produce coal;
2. That at approximately 6:30, he transported a sick person to the surface and observed Mr. Halcomb and Mr. Brooks on the surface working on a belt drive;
3. That he returned to the 2 Right Section and resumed normal mining activities until he was informed of the accident;
4. That at approximately 8:30 p.m., he was notified of the accident by Mr. Middleton and that he and other mine personnel traveled immediately to the accident location;
5. That he and other mine personnel met Mr. Brooks as they were traveling toward the accident scene;
6. That he and other mine personnel began cardiopulmonary resuscitation (CPR) immediately upon their arrival at the accident scene;
7. That as he and other mine personnel performed CPR on Mr. Halcomb, Mr. Middleton traveled to the 2 Right Section to obtain first aid equipment, including a backboard and an automatic external defibrillator (AED);
8. That he and Mr. Wayne Glover, roof bolter operator, attached the AED to Mr. Halcomb, but the AED advised “No Shock” by voice prompt;
9. That he continued CPR on Mr. Halcomb while he was being transported to the surface;
10. That upon their arrival on the surface with Mr. Halcomb, they continued CPR and reconnected the AED to Mr. Halcomb;
11. That after reconnecting the AED to Mr. Halcomb, the AED advised “No Shock” a couple times by voice prompt;
12. That Appalachia Rescue Squad personnel arrived shortly thereafter and the AED responded “Shock Advised”, and that Mr. Halcomb was defibrillated three times by rescue squad personnel.

**Rondall Middleton – Bridge Operator stated:**

1. That he traveled by Mr. Halcomb and Mr. Brooks when they were located at the No. 4 VCB high voltage splitter box;
2. That as he was returning to the 2 Right Section, he met Mr. Brooks approximately 150 feet outby the No. 4 high voltage splitter box and that Mr. Brooks informed him about the accident;
3. That he returned to the accident scene with Mr. Brooks and administered first aid to Mr. Halcomb, as Mr. Brooks went to a mine telephone to call the 2 Right Section personnel for help;
4. That upon his arrival at the accident scene, he attempted to get a response from Mr. Halcomb but was unsuccessful;
5. That Mr. Brooks returned to the accident scene and informed him that he was unsuccessful in contacting the 2 Right Section personnel;
6. That Mr. Brooks informed him that he would travel to the 2 Right Section to get help;
7. That after Mr. Brooks departed the accident scene, he went to the mine telephone and contacted the 2 Right Section personnel informing them about the accident;
8. That he contacted surface personnel reporting the accident and requested an ambulance, after he had contacted the 2 Right Section personnel;

9. That after reporting the accident to the 2 Right Section and surface personnel, he returned to the accident scene and continued administering first aid to Mr. Halcomb while awaiting arrival of Mr. Brooks and the 2 Right Section personnel;
10. That after Mr. Edwards and other mine personnel arrived and started cardiopulmonary resuscitation (CPR), he traveled to the 2 Right Section and obtained first aid equipment, including an automatic external defibrillator (AED).

**Edward Creech – Mine Superintendent stated:**

1. That his employment at this mine began in November, 2003, as mine superintendent;
2. That he was very limited in electrical knowledge, was not an electrician and that the only affiliation he had with electrical equipment was assisting Mr. Duncan in making decisions where such equipment, including high voltage transformers, would be installed in the mine;
3. That he and Mr. Tommy Duncan, Chief Electrician, were responsible for assigning work to Mr. Halcomb and Mr. Brooks;
4. That prior to the beginning of their shift on September 24, 2004, he had a discussion with Mr. Halcomb and Mr. Brooks on their assigned work on the shift of the accident, which included making electrical connections at the newly installed high voltage belt transformer, located on the (new) 3 Right Section and at the No. 4 VCB high voltage splitter box, but not to energize this circuit as this circuit was scheduled to be energized and tested on the next (third) shift because maintenance work was performed on the third shift;
5. That he did not know who moved the No. 4 VCB high voltage splitter box underground or when the splitter box was put into service at the location where the accident occurred;
6. That he did not know when or who changed the high voltage electrical connections at the No. 5 high voltage belt transformer and No. 4 VCB high voltage splitter box where the accident occurred;
7. That he did not know when or who may have installed the “dust cover” over the No. 4 VCB high voltage splitter box feed-through female receptacle involved in the accident, as this electrical system is required to have a “terminator cover” installed over the feed-through female receptacle for the ground/ground-monitoring system to operate properly if the system is maintained as designed.
8. That he did not know when or who may have installed the “terminator cover” over the “output” female receptacle, located on the opposite end and in-line with the female receptacle on the No. 4 VCB high voltage splitter box, as a “dust cover” is the proper type cover to be placed over this “output” side;
9. That he was not familiar with the purpose, presence or absence of an “alignment guide screw”, located on the No. 5 high voltage belt transformer female receptacle, where the ground monitor pin was bent in the male coupler.

**Tommy Duncan – Chief Electrician stated:**

1. That his position as maintenance superintendent included assigning various mining personnel necessary work to maintain and examine electrical equipment including weekly and monthly electrical equipment examinations, monthly high voltage circuit breaker examinations and testing, and daily maintenance and electrical work;
2. That Mr. Brooks was the only certified electrical repairman employed on the evening shift;
3. That he had assigned Mr. George Miller, third shift electrical repairman, to perform monthly examinations of high voltage circuit breakers;
4. That high voltage work was usually performed on the third (maintenance) shift;
5. That Mr. Miller is responsible for and performs most of the high voltage work at the mine on the third shift;
6. That he assigned Mr. Halcomb and Mr. Brooks the work to be performed on the shift of the accident;
7. That he instructed Mr. Halcomb and Mr. Brooks to make preparations for providing high voltage electrical power to the (new) 3 Right Section high voltage belt transformer;
8. That the work he assigned to Mr. Halcomb and Mr. Brooks was to “prepare”, which included cleaning and connecting high voltage cables at the newly installed high voltage belt transformer, located on the (new) 3 Right Section and at the No. 4 VCB high voltage splitter box that would provide power to the new section belt transformer;
9. That he instructed Mr. Halcomb and Mr. Brooks to make the high voltage electrical connections at the (new) 3 Right Section high voltage belt transformer and the No. 4 VCB high voltage splitter box, but not to energize this circuit as it was scheduled to be energized and tested on the next (third) shift;
10. That he did not give specific directions to Mr. Halcomb and Mr. Brooks about which end of the No. 4 VCB high voltage splitter box that they would be performing work on;
11. That Mr. Brooks called him at home at approximately 7:00 p.m. asking him about the correct type of “terminator cover” for the newly installed belt transformer located at the (new) 3 Right Section, and he informed Mr. Brooks the type cover he had found was correct if it had a ground monitoring pin;
12. That he did not know who moved the No. 4 VCB high voltage splitter box from the surface to underground or when the splitter box was put into service at the location where the accident occurred;
13. That he did not know when or who changed the electrical connections for the incoming high voltage power from the surface to the No. 4 VCB high voltage splitter box and the No. 5 high voltage belt transformer that was changed sometime between July 21, 2004, (installation date) and August 22, 2004, when Mr. Miller conducted the last monthly examination of high voltage circuit breakers at this location;
14. That he did not know when or who may have installed the “dust cover” over the No. 4 VCB high voltage splitter box feed-through female receptacle involved in the accident;
15. That he did not know when or who may have installed the “terminator cover” over the “output” female receptacle, located on the opposite end and in-line with the female receptacle on the No. 4 VCB high voltage splitter box, as a “dust cover” is the proper type cover to be placed over this “output” receptacle;

16. That he was not involved with installing and connecting the No. 4 VCB high voltage splitter box and No. 5 high voltage belt transformer and had never disconnected or reconnected the No. 5 high voltage belt transformer “feed-through” male coupler; therefore, he did not know why the “alignment guide” screw in the female receptacle was missing;
17. That he did not know who was involved, when or how the “ground monitor pin”, located in the No. 5 high voltage belt transformer “feed-through” male coupler, was bent, short-circuiting the ground/ground monitoring electrical circuit from the No. 4 VCB high voltage splitter box to the surface high voltage circuit breaker electrical circuit;
18. That he personally had never activated the “emergency stop” device on the No. 4 VCB high voltage splitter box.

**George Miller – Third Shift Repairman stated:**

1. That he was in-charge of scheduling and assigning maintenance and electrical work to other third shift mine personnel;
2. That he was assigned to conduct required monthly examinations of high voltage circuit breakers, which included activating “emergency stop” devices on various high voltage transformers to ensure the complete high voltage ground/ground-monitoring electrical system was operating properly, and he also rotated the applicable high voltage disc relays located at the surface high voltage substation to verify proper operation;
3. That he assisted other mine personnel in positioning the No. 4 VCB high voltage splitter box at the location where the accident occurred but could not remember when the splitter box was installed;
4. That he completed the electrical connections for the incoming high voltage power from the surface to the No. 4 VCB high voltage splitter box and No. 5 high voltage belt transformer on approximately July 21, 2004, but he could not remember specifically when the connections were made or when the splitter box was energized and put into service;
5. That on August 22, 2004, when he activated the “emergency stop” device located on the No. 4 VCB high voltage splitter box, as part of monthly examinations of high voltage circuit breakers, that the electrical connections for the incoming high voltage power from the surface to the No. 4 VCB high voltage splitter box and No. 5 high voltage belt transformer had been changed from the way he had originally connected the high voltage cables on approximately July 21, 2004;
6. That he thought Mr. Brooks may have changed the electrical connections on the incoming high voltage power from the surface to the No. 4 VCB high voltage splitter box and No. 5 high voltage belt transformer;
7. That on August 22, 2004, when he conducted monthly examinations of high voltage circuit breakers, by activating the “emergency stop” device on the No. 4 VCB high voltage splitter box, the device operated properly by deenergizing the high voltage power at the surface high voltage substation;
8. That when shown an electrical schematic of the incoming high voltage power source, No. 4 VCB high voltage splitter box and No. 5 high voltage belt transformer when the accident occurred, that this was the way that the incoming high voltage power from the surface to the No. 5 high voltage belt transformer and the No. 4 VCB high voltage splitter

box was connected when he conducted monthly examinations of high voltage circuit breakers on August 22, 2004;

9. That he had not observed a “dust cover” had been improperly installed over the No. 4 VCB high voltage splitter box “feed-through” female receptacle involved in the accident, and he had not observed that a “terminator cover” had been improperly installed over the “output” female receptacle located on the opposite end of the splitter box in-line with the female receptacle involved in the accident;
10. That on August 22, 2004, when he activated the “emergency stop” device on the No. 4 VCB high voltage splitter box, he did not observe that the “dust cover” and “terminator cover” had been reversed sometime after he completed the original electrical connections on approximately July 21, 2004;
11. That he was not familiar with the presence or absence of an “alignment guide” screw in the No. 5 high voltage belt transformer “feed-through” female receptacle.

## PHYSICAL FACTORS

The physical factors at the scene of the accident revealed the following:

1. The electrical accident occurred at the No. 4 vacuum circuit breaker (VCB) high voltage feed-through splitter box, located in a crosscut adjacent to No. 3 entry in the Mains haulway at the intersection of survey station number 12405.
2. The victim came in contact with one phase of an energized 7,200 volt, phase-to-phase, alternating current (AC) circuit in a feed-through female receptacle, located on the input/feed-through end of the No. 4 VCB high voltage feed-through splitter box.
3. The incoming high voltage power source from the surface was not deenergized when the accident occurred. Mr. Halcomb and Mr. Brooks were unknowingly working on an energized high voltage power source at the No. 4 VCB high voltage splitter box female receptacle. The disconnecting device located on the surface was the only means to deenergize the high voltage power source to the No. 4 VCB high voltage splitter box female receptacle involved in the accident. The high voltage power source located on the surface should have been deenergized, suitably tagged, locked out and grounded prior to anyone performing work on the splitter box female receptacle involved in the accident, as required by the Coal Mine Safety Laws of Virginia, Section 45.1-161.196.
4. The No. 4 VCB high voltage splitter box, serial No. 10160 – 397, was manufactured by American Electric Equipment, Inc., located in Beckley, West Virginia.
5. The No. 4 VCB high voltage splitter box was delivered to this mine from another company owned mine and was taken underground on an undetermined date, at least several months prior to June 16, 2004. Mine personnel could not determine the exact date that the splitter box was initially taken underground and put into service. The splitter box was removed from underground and brought to the surface area of the mine on June 16, 2004. The splitter box was energized and used while located on the surface. The splitter box was taken back underground for the second time on July 21, 2004, and installed at survey station number 12405 where the accident occurred. Mine personnel could not determine the exact date that electrical connections were completed or when the box was actually put into service.
6. High voltage cables purchased for use at this mine are equipped with coupling devices located on each end of the cable. A male coupling device is installed on one end and a female coupling device is installed on the other end.
7. The No. 4 VCB high voltage splitter box was designed to deliver two individual “output” high voltage circuits. The input/feed-through end of the box has one female receptacle identified as “feed-through” and one male receptacle identified as “input” as both were labeled by the manufacturer. The input end of the box was being used to receive high voltage power from the No. 5 high voltage belt transformer. The female receptacle located where the accident occurred is identified as a “feed-through” circuit and is designed to provide an extension of the high voltage power input, if needed. The input and feed-through high voltage circuits are parallel connected and are directed through a vacuum circuit breaker (VCB) and a visual disconnecting device that provides power to two individual high voltage “output” female receptacles located on the output end of the box. High voltage power travels through the “input” male receptacle, parallels across to the feed-through female receptacle and then to each individual vacuum circuit breaker,



disconnecting device and corresponding “output” female receptacle. The splitter box is designed such that either high voltage circuit connected to the “outputs” can be deenergized with the vacuum circuit breaker and disconnecting device and can be grounded without affecting the other high voltage power output circuit.

8. The No. 4 VCB high voltage splitter box was located end to end with the No. 5 high voltage belt transformer, serial No. 8260, and both were located in the same crosscut.
9. The mining height at the No. 4 VCB high voltage splitter box where the accident occurred was 72 inches.
10. Mine personnel were conducting second mining operations on the 2 Right Section and were near completion. The 2 Right Section was located approximately 3,525 feet from the surface. The No. 4 VCB high voltage splitter box was located 2,175 feet from the surface. The distance from the 2 Right Section belt conveyor loading point and the No. 4 VCB high voltage splitter box was 1,350 feet.
11. A high voltage belt transformer had been recently installed on the Mains near where the (new) 3 Right Section would be started. Mr. Halcomb and Mr. Brooks were making preparations to connect high voltage power, from the recently installed high voltage belt transformer located near the (new) 3 Right Section to the No. 4 VCB high voltage splitter box where the accident occurred.
12. During the investigation, the following electrical conditions were observed on the right side of the No. 4 VCB high voltage splitter box:
  - The No. 4 VCB high voltage splitter box was energized;
  - The control power circuit breaker was in the open (deenergized) position;
  - The vacuum circuit breaker (VCB) was in the open (deenergized) position;
  - The visual disconnecting device was in the open (deenergized) position.
13. The following is an electrical configuration description of how the high voltage connections were made when the accident occurred and also describes the electrical configuration as verified by Mr. Miller when he conducted monthly examinations of high voltage circuit breakers at this location on August 22, 2004:
  - The incoming high voltage power from the surface was connected by a female coupler attached to the high voltage cable to a male receptacle (labeled “input”) located on the No. 5 high voltage belt transformer that provided a 7,200 volt power source. The high voltage power was parallel connected inside the No. 5 belt transformer, which provided 7,200 volts to a female receptacle (labeled “feed-through”) that was connected to a high voltage jumper cable. (*See Electrical Schematic No. 1*)
  - The high voltage jumper cable was connected to a female receptacle, located on the No. 5 high voltage belt transformer, that provided the 7,200 volt power source to an input male receptacle located on the No. 4 VCB high voltage splitter box. With this electrical configuration, the No. 4 VCB high voltage splitter box received high voltage power from the No. 5 high voltage belt transformer. (*See Electrical Schematic No. 1*)
  - The “input” high voltage circuit, located inside the No. 4 VCB high voltage splitter box, provided feed-through power to two parallel connected high voltage circuits. The input circuit located on the left side of the splitter box, as observed from the input/feed-through end of the box, was directed through a vacuum circuit

breaker (VCB) and a visual disconnecting device and provided the high voltage power source for the 2 Right Section high voltage transformer.

The feed-through circuit located on the right side of the splitter box, as observed from the input/feed-through end of the box, was planned to be used to provide power to the (new) 3 Right Section high voltage belt transformer. (*See Electrical Schematic No. 1*)

14. A “dust cover” was observed over the female receptacle, which provided the 7,200 volt power source involved in the accident. Mr. Brooks stated that he had removed a “dust cover” from this receptacle when he and Mr. Halcomb arrived at this location to perform their assigned work. Mr. Brooks also stated that he had reinstalled a “dust cover” over this female receptacle as mine personnel were administering first aid treatment to Mr. Halcomb. Three other dust covers were observed lying on the mine floor near the right corner of the splitter box where the accident occurred. (*See Electrical Schematic No. 1*)
15. The high voltage input power circuit provided 7,200 volts that was parallel connected directly to the female receptacle involved in the accident. The circuit, located on the right side of the input/feed-through end of the No. 4 VCB high voltage splitter box, was connected through a vacuum circuit breaker (VCB) and a visual disconnecting device and provided a high power source for an “output” female receptacle, located on the “output” end of the box. (*See Electrical Schematic No. 1*)
16. The No. 5 high voltage belt transformer was located end to end with the No. 4 VCB high voltage splitter box. The incoming high voltage power source from the surface was connected to the “input” of the belt transformer and provided a parallel connected 7,200 volt power source to a feed-through receptacle. A high voltage jumper cable was connected to this feed-through receptacle, which provided high voltage power to the input receptacle located on the No. 4 VCB high voltage splitter box. The No. 5 high voltage belt transformer contained also “step-down” transformers that reduced 7,200 volts to low voltage circuits (120-220-480 volts) that was being utilized to power belt drives, a belt conveyor take up unit, water pumps, lights, etc.
17. The configuration of electrical connections of the incoming high voltage power from the surface to the No. 4 VCB high voltage splitter box and the No. 5 high voltage belt transformer had been changed sometime after July 21, 2004 (installation date) and before August 22, 2004, when Mr. Miller conducted the last monthly examination of high voltage circuit breakers at this location. The configuration of electrical connections that Mr. Miller observed on August 22, 2004, was the same configuration that was in place when the accident occurred. The following is an electrical configuration description of how the high voltage connections were made on July 21, 2004, when Mr. Miller made the high voltage electrical connections at the No. 4 VCB high voltage splitter box and the No. 5 high voltage belt transformer:
  - The incoming high voltage power from the surface was connected by a female coupler installed on the high voltage cable to the male receptacle (labeled “input” on the No. 4 VCB high voltage splitter box. This “input” power source provided feed-through high voltage power to two “output” female receptacles located on the opposite end of the box. (*See Electrical Schematic No. 2*)
  - Each of the input and feed-through high voltage circuits was directed through a vacuum circuit breaker and a visual disconnecting device that provided 7,200

volts to each of two “output” female receptacles. (*See Electrical Schematic No. 2*)

- A male coupler, attached to one end of a high voltage cable, was connected to one of the “output” female receptacles located on the No. 4 VCB high voltage splitter box and was used to provide 7,200 volts to the 2 Right Section high voltage section transformer. A high voltage jumper cable was used to provide a power source from the other “output” receptacle located on the No. 4 VCB high voltage splitter box to an “input” male receptacle located on the No. 5 high voltage belt transformer. At this time, the No. 5 high voltage belt transformer received high voltage power from the No. 4 VCB high voltage splitter box through the jumper cable. (*See Electrical Schematic No. 2*)
18. The No. 4 VCB high voltage splitter box is electrically designed for personal safety reasons such that a “dust cover” or a “terminator cover” is required to be installed over a specific type receptacle. These two metal covers are totally different and are specially designed for different purposes. The only similarity is that the size and threads are the same which allows the covers to be mistakenly interchanged, but the covers cannot be interchanged if the applicable ground/ground monitoring system is operating properly or unless the ground/ground monitoring system has a “short circuit”. When this accident occurred, the No. 4 VCB high voltage splitter box ground/ground monitoring system was not operating properly because a “short circuit” had occurred outby at the No. 5 high voltage belt transformer male coupler that provided high voltage power to the No. 4 VCB high voltage splitter box. The underground ground/ground monitoring system consists of a ground conductor and a ground monitoring conductor that originates at the surface high voltage substation and is connected to various electrical circuits and equipment in the mine. This safety system consists of a series circuit that is connected to various electrical circuits and equipment to continuously monitor continuity of the ground/ground monitoring conductors. If this series circuit is interrupted for any reason, then the applicable high voltage circuit will deenergize automatically. “Terminator covers”, high voltage transformer lid switches and transformer emergency stop devices are examples of safety designed interruptions that will automatically deenergize the applicable high voltage circuit when activated. If a “terminator cover” is mistakenly removed with the high voltage circuit energized, the removal interrupts continuity of the series connected ground/ground monitoring circuit, then the applicable high voltage circuit will deenergize automatically if the ground/ground monitoring system is operating properly. A “dust cover” is normally installed over “output” female receptacles and a “terminator cover” is installed over “feed-through” female receptacles. A “terminator cover” is specially designed to protect mine personnel against exposure to energized high voltage circuits and to deenergize the applicable high voltage circuit if the cover is removed by mistake. A “dust cover” is a plain cover that contains no internal components and simply screws onto and covers an output receptacle. A “terminator cover” has internal components designed for personal safety and consists of a ground pin and a ground monitoring pin. These ground and ground monitoring pins are an integral part of the safety grounding system that have specific design characteristics. The ground and ground monitoring pins located inside a “terminator cover” are designed so that when the cover is removed, the ground monitoring pin will break contact (disconnect) first and the ground pin will break contact (disconnect) last. As soon as the ground monitoring pin breaks contact, the

ground/ground monitoring series circuit is interrupted causing the applicable high circuit breaker to deenergize automatically. As long as the circuit created by the ground and ground monitoring pins is complete, the high voltage circuit remains energized but if this circuit is interrupted for any reason, such as removing a “terminator cover” by mistake, then the applicable high voltage circuit will automatically deenergize if the system is operating properly.

19. A “terminator cover” was observed over the “output” female receptacle located on the output end of the No. 4 VCB high voltage splitter box. This female receptacle and “terminator cover” were located on the same side of the splitter box as the female receptacle involved in the accident. Mr. Miller observed a “terminator cover” over the female receptacle involved in the accident at the following times:

- when the splitter box was located on the surface after June 16, 2004;
- when the splitter box was taken back underground on July 21, 2004;
- when the splitter box was installed, connected and energized underground after July 21, 2004;
- when he activated the emergency stop device on the No. 4 VCB high voltage splitter box on August 22, 2004;

This “terminator cover” located on the output end and “dust cover” located on the input/feed-through end of the No. 4 VCB high voltage splitter box had been mistakenly reversed. Mr. Miller stated that a “terminator cover” was intact over the No. 4 VCB high voltage splitter box female receptacle involved in the accident when he activated the emergency stop device on August 22, 2004. The “terminator cover” and “dust cover” apparently had been reversed sometime after August 22, 2004. On August 22, 2004, Mr. Miller conducted a monthly examination of high voltage circuit breakers at this location by activating the emergency stop device on the No. 4 VCB high voltage splitter box, and at this time the ground/ground monitoring circuit operated properly by deenergizing the high voltage circuit breaker located on the surface.

If the ground/ground monitoring circuit located in the No. 4 VCB high voltage splitter box had been operating properly and the “terminator cover” was removed whether intentional or by mistake, then the high voltage circuit breaker located on the surface would have deenergized automatically, as the system is designed to do. Also, the ground monitor pin, located in the No. 5 high voltage belt transformer male coupler that provided electrical power to the No. 4 VCB high voltage splitter box, could not have been bent against the male coupler frame on August 22, 2004, or else the emergency stop device located on the splitter box would not have operated.

20. The ground monitor pin located in the No. 5 high voltage belt transformer male coupler that provided electrical power to the No. 4 VCB high voltage splitter box was bent against the coupler housing. This pin was in direct contact with the male coupler housing, which resulted in a “short-circuit” of the ground/ground monitoring circuit at this point. This pin must have been bent after August 22, 2004, because on this date Mr. Miller activated the emergency stop device on the No. 4 VCB high voltage splitter box and the device operated properly.

21. Different brands of male couplers and female receptacles are used both on the surface and underground at this mine. Some, but not all brands of couplers and receptacles being used at the mine were designed with “alignment guide” screws and “slots” to assist in providing proper alignment when male to female connections are made. The high

voltage male coupler and female receptacle being used at the No. 5 high voltage belt transformer feed-through receptacle, was originally designed to have an “alignment guide” screw mounted in the female receptacle and a “slot” in the male coupler. The purpose of the “alignment guide” screw in the female receptacle and “slot” in the male coupling is that the screw slides into the slot to maintain proper alignment of the three phase conductor pins, ground pin and ground monitor pin, located in the male coupler with the applicable female components located in the female receptacle. The No. 5 high voltage belt transformer female receptacle observed during the investigation was designed but not equipped with an “alignment guide” screw. The absence of an “alignment guide” screw in the No. 5 high voltage belt transformer female receptacle that was connected to the high voltage jumper cable, which provided high voltage power to the No. 4 VCB high voltage splitter box input, most likely contributed to improper alignment of the ground monitor pin located in the male coupler. This misalignment of the ground monitor pin in the male coupler resulted in it being bent against the coupler housing, which caused a “short circuit” of the ground/ground monitoring circuit at this location. From the time that the bent ground monitor pin created a “short circuit” at the male coupler housing, the No. 4 VCB high voltage splitter box was not continuously monitored. Also, from the time that the ground monitor pin was bent causing the “short circuit” of the ground/ground monitoring circuit at this location, the emergency stop device located on the No. 4 VCB high voltage splitter box would not operate. Mine personnel would not have known that this pin was bent, until Mr. Miller or other mine personnel activated the emergency stop device located on the No. 4 VCB high voltage splitter box. This emergency stop device was required to be activated by September 30, 2004, to comply with monthly examinations of high voltage equipment as referenced in 45.1-161.195 A, Coal Mine Safety Laws of Virginia. At this time when the emergency stop device was activated, it would not have operated to deenergize the high voltage circuit breaker located at the surface substation. When the ground monitor pin was bent, causing a “short circuit” of the ground/ground monitoring circuit, mine personnel would not have known because the high voltage system would operate as normal until someone activated the emergency stop device located on the No. 4 VCB high voltage splitter box and in which case the emergency stop device would not operate.

22. The 7,200 volt high voltage system remained energized when the accident occurred.
23. The following is a description of how the high voltage power system was routed from the surface substation to the No. 4 VCB high voltage splitter box and No. 5 high voltage belt transformer. The high voltage power is routed from the surface substation to a high voltage capacitor box. The high voltage power exits the capacitor box and enters a visual disconnecting box. The visual disconnecting box, serial No. 9450, was manufactured by Line Power Manufacturing Corporation. The high voltage power exits the visual disconnecting box and enters a surface high voltage transformer, serial No. 10155-1850-297. This surface transformer, rated at 1850 kilovoltamps (KVA), was manufactured by American Electric Company. The high voltage power was then routed underground to the No. 5 high voltage belt transformer and onto the No. 4 VCB high voltage splitter box where the accident occurred.

24. The following is a description of events, electrical examinations and tests that progressed during the on-site investigation conducted on September 25, 2004:

- The high voltage power was deenergized, tagged, locked out and grounded on the surface;
- A “dust cover” was removed from the No. 4 VCB high voltage splitter box female receptacle involved in the accident;
- The underground high voltage was energized and remained energized without a “terminator cover” installed on the No. 4 VCB splitter box feed-through female receptacle where the accident occurred, which indicated a problem with the ground/ground monitoring circuit;
- The emergency stop device, located on the No. 4 VCB high voltage splitter box, was activated but did not operate to deenergize the high voltage circuit breaker located on the surface, and the underground high voltage power remained energized;
- The emergency stop device located on the No. 5 high voltage belt transformer was activated and the high voltage circuit breaker located on the surface deenergized automatically;
- The high voltage power was again deenergized, tagged, locked out and grounded on the surface;
- The high voltage jumper cable male coupler was disconnected from the No. 5 high voltage belt transformer. This jumper cable was used to provide high voltage power to the “input” receptacle located on the No. 4 VCB high voltage splitter box;
- The investigation team observed the problem with the ground/ground monitoring circuit for the No. 4 VCB high voltage splitter box. The ground monitor pin located in the No. 5 high voltage belt transformer feed-through male coupler was bent against the coupler housing, which resulted in a “short circuit” of the ground/ground monitoring circuit at this point. This “short circuit” caused a failure of the ground/ground monitoring system in the No. 4 VCB high voltage splitter box;
- The bent ground monitor pin was repaired and the male coupler was reconnected;
- A “terminator cover” was installed over the No. 4 VCB high voltage splitter box feed-through female receptacle where the accident occurred;
- High voltage power was restored underground to the No. 4 VCB high voltage splitter box and No. 5 high voltage belt transformer;
- The emergency stop device located on the No. 4 VCB high voltage splitter box was activated, and the high voltage circuit breaker located on the surface deenergized automatically verifying that the ground/ground monitoring circuit was operating properly;
- The emergency stop device located on the No. 5 high voltage belt transformer was activated again, and the high voltage circuit breaker located on the surface deenergized automatically.

## CONCLUSION

On September 24, 2004, at approximately 8:30 p.m., an underground high voltage electrical power accident occurred at Cumberland River Coal Company, Fork Ridge Mine, Mine Index No. 14718AA. Mr. Leonard Halcomb, face equipment operator, was fatally injured when he came in contact with one phase of an energized 7,200 volt, phase to phase, high voltage terminal located in a high voltage feed-through splitter box female receptacle. Mr. Halcomb and a coworker were cleaning and preparing a high voltage female receptacle and a male coupler that were to be connected and were scheduled to be energized on the next shift to provide electrical power to a new working section high voltage belt transformer. Mr. Halcomb and Mr. Brooks, repairman, failed to recognize that the high voltage feed-through circuit was located on the female receptacle end of the splitter box where the accident occurred.

## ENFORCEMENT ACTION

The following enforcement action was taken as a result of the investigation:

1. An order of closure, No. MRM0000730, was issued under Section 45.1-161.91. A. (ii), of the Coal Mine Safety Laws of Virginia on the entire mine necessary to preserve the scene of the accident pending an investigation. The order of closure was modified to allow implementation of an action plan developed in response to the fatal accident and for the mine to resume full production.
2. An order of closure, No. SDF0004086, was issued under Section 45.1-161.91. A. (i), referencing 45.1-161.196. of the Coal Mine Safety Laws of Virginia. A fatal accident occurred on September 24, 2004, at approximately 8:30 p.m. Mr. Leonard Halcomb, face equipment operator, received fatal injuries when he came in contact with one phase of an energized 7,200 volt alternating current underground high voltage power circuit at the No. 4 VCB high voltage feed-through splitter box, serial No. 10160-397. An imminent danger was present in that work was being performed on an energized high voltage circuit that had not been deenergized, tagged, locked out and grounded. The Coal Mine Safety Laws of Virginia, Section 45.1-161.196 requires that all high voltage circuits shall be deenergized, suitably tagged, locked out and grounded before repair work is performed.
3. A notice of violation, No. SDF 0004087, was issued under Section 45.1-161.188.C. of the Coal Mine Safety Laws of Virginia. A fatal accident occurred on September 24, 2004, at approximately 8:30 p.m. Mr. Leonard Halcomb, face equipment operator, received fatal injuries when he came in contact with one phase of an energized 7,200 volt alternating current underground high voltage power circuit at the No. 4 VCB high voltage feed-through splitter box, serial No. 10160-397. This fail-safe ground check circuit designed to continuously monitor the grounding circuit from the male coupler located on the No. 5 belt transformer to the female receptacle involved in the accident was not maintained as designed. The ground monitor pin located in the No. 5 belt transformer male coupler that provided electrical power to the No. 4 VCB high voltage feed-through splitter box, was bent against the male coupler metal housing, causing the ground/ground monitoring system to short circuit at this location. This short circuit of the ground monitoring system prevented continuous monitoring of the ground/ground monitoring circuit from the male coupler located on the No. 5 belt transformer to the female receptacle involved in the accident. The Coal Mine Safety Laws of Virginia, Section 45.1-161.188.C. requires that all resistance-grounded alternating current circuits used

underground shall include a fail-safe ground check circuit to continuously monitor the grounding circuit to assure continuity of the ground conductor.

4. A notice of violation, No. SDF0004139, was issued to Mr. Rodney Brooks, repairman, under 45.1-161.196. of the Coal Mine Safety Laws of Virginia. A fatal accident occurred on September 24, 2004, at approximately 8:30 p.m. Mr. Leonard Halcomb, face equipment operator, received fatal injuries when he came in contact with one phase of an energized 7,200 volt alternating current high voltage power circuit at the No. 4 VCB high voltage feed-through splitter box, serial No. 10160-397. Mr. Halcomb was not certified as an electrical repairman in Virginia. Statements obtained from mine personnel during interviews conducted on September 27, 2004, revealed that Mr. Rodney Brooks, Virginia certified electrical repairman, certification number 02048, and Mr. Halcomb were performing work on the No. 4 splitter box. On September 24, 2004, the visual disconnecting device located near the surface substation that provided electrical power to the underground high voltage circuit was not locked out, suitably tagged and grounded by the person performing electrical work on the No. 4 VCB high voltage splitter box female receptacle. The disconnecting device located on the surface was the only means to deenergize and disconnect the circuit. Mr. Halcomb performed electrical work on the underground high voltage circuit without locking out, tagging and grounding the proper disconnecting device. The visual disconnects to the unused output of the No. 4 VCB high voltage splitter box had been opened (deenergized) by Mr. Brooks, who mistakenly thought electrical power to the female receptacle, on which Mr. Halcomb was working when the accident occurred, had been deenergized. The Coal Mine Safety Laws of Virginia, Section 45.1-161.196 requires that all high voltage circuits shall be deenergized, suitably tagged, locked out and grounded before repair work is performed.

## **RECOMMENDATIONS**

1. No electrical work shall be performed on low, medium, or high voltage distribution circuits or equipment, except by a certified person or by a person trained to perform electrical work and to maintain electrical equipment under the direct supervision of a certified person.
2. Ensure the correct disconnecting device(s) is locked out and suitably tagged by the persons who perform electrical or mechanical work on such circuits or equipment connected to the circuits.
3. All high-voltage circuits shall be grounded before repair work is performed. The certified electrical repairman shall effectively ground the high voltage circuit prior to performing any work on the deenergized circuit.
4. Be familiar with any high voltage unit containing a feed through circuit; observe and understand the safety precautions and labeling displayed on the unit.



## **SIGNATURE SHEET**

This report is hereby submitted by Daniel Perkins and approved by Frank A. Linkous.

---

DANIEL PERKINS, TECHNICAL SPECIALIST

DATE

---

FRANK A. LINKOUS, CHIEF

DATE

## **APPENDIX**

VICTIM DATA SHEET

PERSONS PRESENT DURING THE INVESTIGATION

MINE LICENSE INFORMATION

**VICTIM DATA SHEET**

Name:	Leonard Halcomb
Occupation:	Face Equipment Operator
Mailing Address:	P.O. Box 682, Dryden, Va 24243
Date of Birth:	November 18, 1952
Total Mining Experience:	Thirty years
Experience with Present Company:	Seven years six months
Experience in Present Occupation:	Seven years six months

## PERSONNEL

The following personnel provided information and/or were present during the investigation and those personnel interviewed are identified with an asterisk (\*):

### CUMBERLAND RIVER COAL COMPANY

Thurman Holcomb	General Manager	
Edward Creech*	Superintendent	
Tony Bumbico	Director of Corporate Safety, Arch Coal, Inc.	
Leroy Mullins	Safety Director	
Robert Lovell*	Repairman/Mine Examiner	Day Shift
Tommy Duncan*	Chief Electrician	Day Shift
Carlos Combs*	Repairman	Day Shift
Reece Maggard	Face Equipment Operator	Day Shift
	President of Scotia Employees Association	
Eddie Bentley*	Repairman/Miner's Representative	Day Shift
Rodney Brooks*	Repairman	Second Shift
Jerry Edwards*	Section Mine Foreman	Second Shift
Wayne Glover*	Roofbolter Operator	Second Shift
Rondall Middleton*	Bridge Operator	Second Shift
George Miller*	Repairman	Third Shift
John Monhollen*	Repairman/Mechanic	Third Shift
Danny Lawson*	Repairman/Mechanic	Third Shift
Greg Hall*	Repairman	Third Shift

### SPILMAN, THOMAS AND BATTLE, PLLC ATTORNEY'S AT LAW

Mark Heath	Attorney
------------	----------

### MINE SAFETY AND HEALTH ADMINISTRATION

Allen Dupree	Assistant District Manager, District 5
Andrew C. Moore	Supervisory, Mine Safety and Health Specialist - Electrical
David Woodward	Mining Engineer
Glen Deel	Coal Mine Safety and Health Inspector - Electrical
Nick Rasnick	Supervisory, Coal Mine Safety and Health Inspector
Jason Lane	Electrical Engineer

## **VIRGINIA DIVISION OF MINES**

Frank Linkous  
Carroll Green  
Dwight Miller  
Robert Garrett  
Daniel Perkins  
David Asbury  
Sammy Fleming  
Danny Mann

Chief, Division of Mines  
Mine Inspector Supervisor  
Coal Mine Technical Specialist  
Coal Mine Technical Specialist  
Coal Mine Technical Specialist  
Mine Technical Engineer  
Coal Mine Inspector  
Coal Mine Inspector

## **MINE LICENSE INFORMATION**

Official Corporation:	Cumberland River Coal Company
Official Business Name of Operator:	Cumberland River Coal Company
Person with Overall Responsibility:	Edward Creech
Person in Charge of Health and Safety:	Edward Creech